

Performance Evaluation and Optimization of Power Quality by Implementing the FACTS System

1Sanjay Shrivastava, 2Dr AK Sharma

1Research Scholar, 2Professor and Head (Department of Electrical Engineering)

1Mahatma Gandhi Chitrakoot, Gramodaya Vishwavidyalaya, Satna

2Jabalpur Engineering College, Jabalpur

Abstract: This paper discusses design and simulation of dynamic voltage restorer for improve power quality & reduce the harmonics distortion of sensitive load. Electronics devices are very sensitive load against harmonics. DVR proposed not only to improve PQ but also to reduce HD due to the presence of non-linear load. The DVR consists of injection transformer, filter, and ESS, VSI and control system. The basic function of injection transformer is to connect the DVR to the distribution network via the HV- wdg. In DVR LC filter can be achieved by eliminating the unwanted harmonics. The ESS can be suitable capacity. The ESS such as battery is responsible to supply energy in DC form. A VSI is a power electronics system consist of switching device which can generate a sinusoidal voltage. The disturbance is carried out with the help of d-q-0 method. Simulation results carried out by MATLAB verify the performance of the given method.

1. Introduction

Power quality problem is an occur as a non-standard voltage, current and frequency. The power quality has serious economic implications for customers, utilities and electrical equipment manufacturers. Modernization and automation of industry involves increasing use of computers, microprocessors and power electronic systems such as adjustable speed drives. Integration of non-conventional generation technologies such as fuel cells, wind turbines and photovoltaic with utility grids often requires power electronic inter-faces. The power electronic systems also contribute to power quality problem (generated harmonics). The electronic devices are very sensitive to disturbances and become less tolerant to power quality problems such as voltage sags, swells and harmonics. Voltage dips are considered to be one of the most severe disturbances to the industrial equipments. Voltage support at a load can be achieved by reactive power injection at the load point of common coupling. Due to the harmonics are occurring in the system it causes losses and heating of motor.

This paper analyses the key issues in the power quality problems, in the proposed system Voltage sag/Voltage swell occurs due to the three phase fault/ground fault/phase to ground fault in the transmission line and harmonics occurs due to the connection of controlled six pulse converter (rectifier) to the main drive load(non linear load). All these factors affect the sensitive load which is connected in parallel to the main drive load. So the proposed system protects the sensitive load by

mitigating the harmonics using dynamic voltage restorer technique.

2. Real life Complications with Power Quality:

a. Transients

These are undesirable but decay with time and hence not a steady state problem. A broad definition is that a transient is that part of the change in a variable that disappears during transition from one steady state operating condition to the other. Another synonymous term is 'surge'.

Transients are classified into two categories:

- (a) Impulsive
- (b) Oscillatory

b. Long Duration Voltage Variations

When RMS (root mean square) deviations at power frequency last longer than one minute, we say they are long duration voltage variations. They can be either over voltages (greater than 1.1 p.u.) or under voltages (less than 0.9 p. u.). Over voltages is usually the result of switching a load or energizing a capacitor bank. Incorrect tap settings on transformers can also result in over voltages. Under voltages are the result of events which are the reverse of events that cause over voltages switching in a load or switching of a capacitor bank.

c. Sustained Interruptions

When the supply voltage has been zero for a period of time greater than one minute, then we say it is a sustained interruption. Generally, voltage interruptions lasting over one minute are often permanent and require human intervention to restore the supply. The term 'outage' used by utilities is synonymous; however it does not bring out the true impact of the power interruption. For a customer with a sensitive load, even an interruption of half a cycle can be disastrous.

d. Voltage Sags

Sag is a decrease of RMS voltage to a value between 0.1 and 0.9 p. u. and lasting for duration between 0.5 cycles to 1 minute. Voltage sags as a voltage dip. Voltage sags are mainly due to system faults and last for durations ranging from 3 cycles to 30 cycles depending on the fault clearing time.

e. Voltage Swells

A voltage swell is defined as an increase to between 1.1 and 1.8 p.u. in RMS voltage at the power frequency for duration between 0.5 cycles to 1 minute. A voltage swell (like sag) is characterized by its magnitude (RMS) and duration. As with sags, swells are associated with system faults. A SLG fault can result in a voltage swell in the unfaulted phases. Swells can also result from energizing a large capacitor bank. The magnitude of a voltage swell depends on the system impedance, fault location and grounding.

f. Voltage Fluctuations and Flicker

Voltage fluctuations are systematic variations of the voltage envelope or a series of random changes in the voltage magnitude (which lies in the range of 0.9 to 1.1 p. u.) High power loads that draw fluctuating current, such as large motor drives and arc furnaces, cause low frequency cyclic voltage variations that result in flickering of light sources (incandescent and fluorescent lamps) which can cause significant physiological discomfort or irritation in human beings.

g. Waveform Distortion

This is defined as a steady-state deviation from an ideal sine wave of power frequency. There are five types of waveform distortion:

- DC offset
- Harmonics
- Inter harmonics
- Notching
- Noise

Enhancement Techniques to improve power quality problems and reduce harmonics distortion:

The solution to the power quality can be done from customer side or from utility side. First approach is called load conditioning, which ensures that the equipment is less sensitive to power disturbances, allowing the operation even under significant voltage distortion. The other solution is to install line conditioning systems that suppress or counteracts the power system disturbances.

To achieve improve power quality is to use passive filters connected at the sensitive load terminals. The challenge is to regulate the sensitive load terminal voltage so that its magnitude remains constant and any harmonic distortion is reduced to an acceptable level. This paper introduces Dynamic voltage restorer and its operating principle. Then a simple control based D-Q-0 method or Park transformation method based on stationary reference frame is used to compensate Harmonics, Voltage sag. At the end MATLAB SIMULINK model based simulated results were presented to validate the effectiveness of the proposed control method of Dynamic voltage restorer.

3. Modeling of Dynamic voltage restorer

Introduction:

Among the power quality problems (sags, swells, harmonics...) voltage sags are the most severe disturbances. In order to overcome these problems the concept of custom power devices is introduced recently. One of those devices is the Dynamic Voltage Restorer (DVR), which is the most efficient and effective modern custom power device used in power distribution networks. The function of the DVR will inject the missing voltage in order to regulate the load voltage from any disturbance due to immediate distort of source voltage. A dynamic voltage restorer (DVR) is a solid state inverter based on injection of voltage in series with a power distribution system. The DC side of DVR is connected to an energy source or an energy storage device, while its ac side is connected to the distribution feeder by a three-phase inter facing injection transformer. A single line diagram of a DVR connected power distribution system is shown in the figure (1). Since DVR is a series connected device, the source current, is same as load current. DVR injected voltage in series with line such that the load voltage is maintained at sinusoidal nominal value. It is normally installed in a distribution system between the supply and the critical load feeder at the point of common coupling (PCC). Other than voltage sags and swells compensation, DVR can also added other features like: line voltage harmonics compensation, reduction of transients in voltage and fault current limitations.

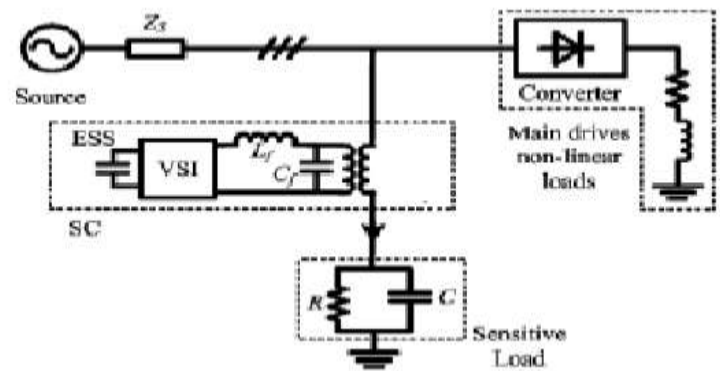

Figure (i)

Basic Configuration of DVR:

The general configuration of the DVR consists of:

- An Injection/ Booster transformer/Isolation transformer
- A Harmonic filter/Passive filter
- Storage Devices/ESS
- A Voltage Source Converter (VSC)/VSI
- DC charging circuit
- A Control and Protection system

a. Injection/ Booster transformer/Isolation transformer-

The Injection / Booster transformer is a specially designed transformer that attempts to limit the coupling of noise and transient energy from the primary side to the secondary side. In a three-phase system, either three single-phase transformer units or one three phase transformer unit can be used for voltage injection purpose. The injection transformer comprises of two side voltages namely the high voltage side and low voltage side. The three single transformers can be connected with star/open star winding or delta/open star winding. The latter does not permit the injection of the zero sequence voltage. The choice of the injection transformer winding depends on the connections of the step down transformer that feeds the load. If a D/Y connected transformer is used, there is no need to compensate the zero sequence voltages. However if Y/Y connection with neutral grounding is used, the zero sequence voltage may have to be compensated. It is essential to avoid the saturation in the injection transformers.

The basic function of the injection transformer is to increase the voltage supplied by the filtered VSI output to the desired level while isolating the DVR circuit from the distribution network. A higher transformer winding ratio will increase the primary side current, which will adversely affect the performance of the power electronic devices connected in the VSI. To evaluate the performance of the DVR the rating of the injection transformer is an important factor that need to be considered due to the compensation ability of the DVR is totally depend on its rating .The DVR performance is totally depend on the rating of the injection transformer , since it limits the maximum compensation ability of the DVR.

b. A Harmonic filter/Passive filter-

The passive filters can be placed either on the high voltage side or the converter side of the injection transformers. Basically filter unit consists of inductor (L) and capacitor (C). In DVR, filters are used to convert the inverted PWM waveform into a sinusoidal waveform. This can be achieved by eliminating the unwanted harmonic components generated by the VSI action. Higher orders harmonic components distort the compensated output voltage. The unnecessary switching harmonics generated by the VSI must be removed from the injected voltage waveform in order to maintain an acceptable Total Harmonics Distortion (THD) level.

c. Storage Devices/ESS-

This is required to provide active power to the load during deep voltage sags. Lead-acid batteries, flywheel or SMES can be used for energy storage. It is also possible to provide the required power on the DC side of the VSI by an auxiliary bridge converter that is fed from an auxiliary AC supply. The DVR need real power for compensation purpose during voltage disturbance in the distribution system. In this case the real power of the DVR must be supplied by energy storage

when the voltage disturbance occurs. The energy storage such as battery is responsible to supply an energy source in D.C form.

d. A Voltage Source Converter (VSC)/VSI-

A VSC is a power electronic system consists of a storage device and switching devices, which can generate a sinusoidal voltage at any required frequency, magnitude, and phase angle. In the DVR application, the VSC is used to temporarily replace the supply voltage or to generate the part of the supply voltage which is missing. This could be a 3 phase - 3 wires VSC or 3 phases - 4 wires VSC. The latter permits the injection of zero-sequence voltages. Either a conventional two level converter (Graetz Bridge) or a three level converter is used. There are four main types of switching devices: Metal Oxide Semiconductor Field Effect Transistors (MOSFET), Gate Turn-Off thyristors (GTO), Insulated Gate Bipolar Transistors (IGBT), and Integrated Gate Commutated Thyristors (IGCT). Each type has its own benefits and drawbacks. The IGBT is a recent compact device with enhanced performance and reliability that allows building VSC with very large power ratings. Because of the highly sophisticated converter design with IGBTs, the DVR can compensate dips which are beyond the capability of the past DVRs using conventional devices. The purpose of storage devices is to supply the necessary energy to the VSC via a dc link for the generation of injected voltages. The different kinds of energy storage devices are Superconductive magnetic energy storage (SMES), batteries and capacitance.

e. DC charging circuit-

The dc charging circuit has two main tasks.

- (i) The first task is to charge the energy source after a sag compensation event.
- (ii) The second task is to maintain dc link voltage at the nominal dc link voltage.

Excess d.c link voltage rise will damage the d.c storage capacitor and switching device. Moreover the rise in d.c link voltage will nonlinearly increase switching loss and lower the DVR system efficiency. Thus aborting the reverse flow of energy is an important issue that needs to be restored. Many research studies in recent year focused on DVR energy optimization.

f. A Control and Protection system-

The aim of the control system is to maintain constant voltage magnitude at the point where a sensitive load is connected, under system disturbances. The harmonics is generated in the load terminals using six pulse converters with fixed firing angle are connected to the main drive non linear load which is parallel to the sensitive load. Voltage sag is created at load terminals via a three phase fault. The above voltage problems are sensed separately and passed through the sequence analyzer. The control system of the general configuration typically consists of a voltage correction method which determines the reference

voltage that should be injected by DVR and the VSI control which is in this work consists of PWM with PI controller. The controller input is an error signal obtained from the reference voltage and the value of the injected voltage (Figure ii & iii). The PI controller processes the error signal and generates the required angle δ . Such error is processed by a PI controller then the output is provided to the PWM signal generator that controls the DVR inverter to generate the required injected voltage.

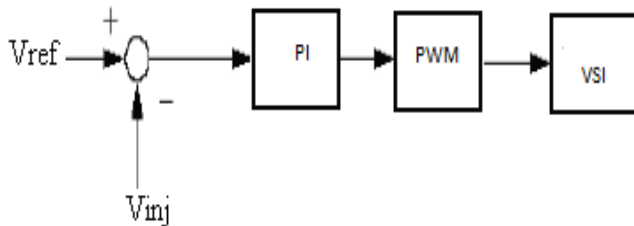

Figure (ii)

4. Operation of DVR

Basic operation of DVR is to transfer the voltage sag compensation value from d.c side of the inverter to the injected transformer after filter. The basic idea of DVR is to inject the missing value cycle into the system through series injection transformer whenever voltage sag are present in the system. The momentary amplitudes of the three injected phase voltages are controlled such as to eliminate any detrimental effects of a bus fault to the load voltage V_L . This means that any differential voltages caused by transient disturbances in the ac feeder will be compensated by an equivalent voltage generated by the converter and injected on the medium voltage level through the booster transformer. Sag is unseen by the load, during normal operation the capacitor receive energy from the main supply source. When voltage diaper sag capacitor deliver d.c supply to the inverter. The inverter ensures that only the missing voltage injected to the transformer. A relatively small capacitor is present a dc side of the VSI. Voltage of over this capacitor is kept constant. The required output voltage is obtained by using PWM switching pattern. As the controller will have to supply active as well as reactive power.

5. Parameter of DVR test system

Table 1. System Parameters

S.No	System Quantities	Standards
1.	Source	3-phase,230V/ph,50Hz
2.	Source Impedance	$L_s=0.005\text{mH}$, $R_s=0.001\text{ohm}$
3.	Injection transformer turn ratio	1:1,230/230V
4.	PI Controller	$K_p=0.5, K_i=50$, Sample time= $50\ \mu\text{s}$
5.	Main Load	Active power=1 MW, Reactive power= 100 VAR
6.	Sensitive Load	Active power=1KW, Reactive power=20VAR
7.	Inverter	IGBT based, 3 arms, 6 pulse, Carrier Frequency=20000 Hz, Sample time= $5\ \mu\text{s}$
8.	Filter Inductance & Capacitance	1mH, 1uF
9.	Battery voltage	100V

6. Simulation Results and Discussions

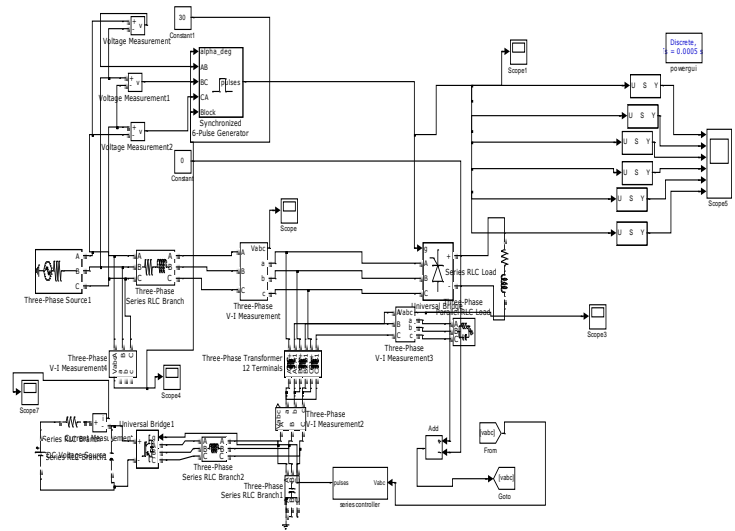

Figure (V)

7. Harmonics issues

In simulink model figure (V) shows the harmonics is generated in the system using six pulse converters connected to the main drive non linear load which is parallel to the sensitive load. The percentage of Total harmonic distortion in the sensitive load side is, in phase1 11.29%, in phase2 15.95%, in phase3 16.70%. In figure (v) MATLAB simulation is carried out **with compensation technique**.

The percentage of total harmonic distortion in the sensitive load side is, in phase1 5.67%, in phase2 5.56%, in phase3 5.92%. The simulation results show that the harmonics in the sensitive load side is decreased approximately to 50%. The simulation results carried out without series compensator, the harmonics generated are 3, 5, 7, 9, 11, 13, 15, 17,19th harmonics in all three phases. The harmonics distortions produced in all the three phases is shown using FFT analysis in figure (VI),

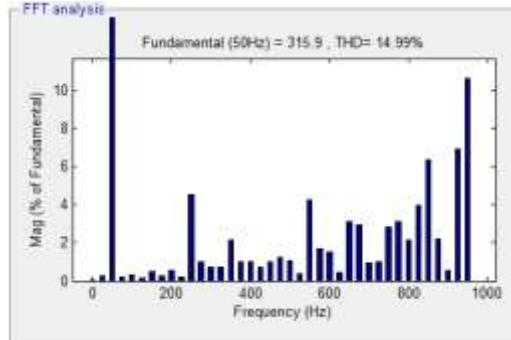
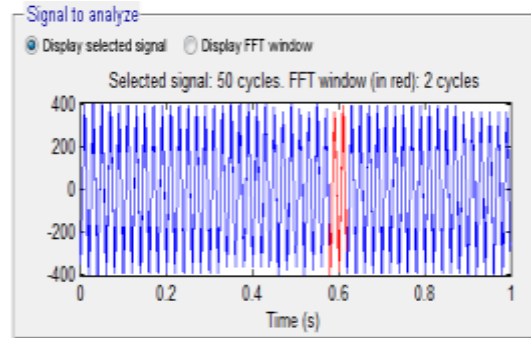

Figure (VI c)
 Figure (VI d)

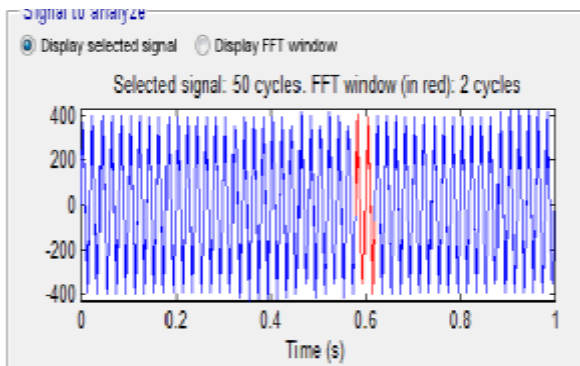

Figure (VI a)

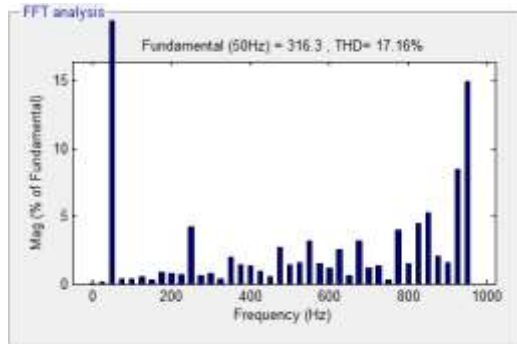

Figure (VI b)

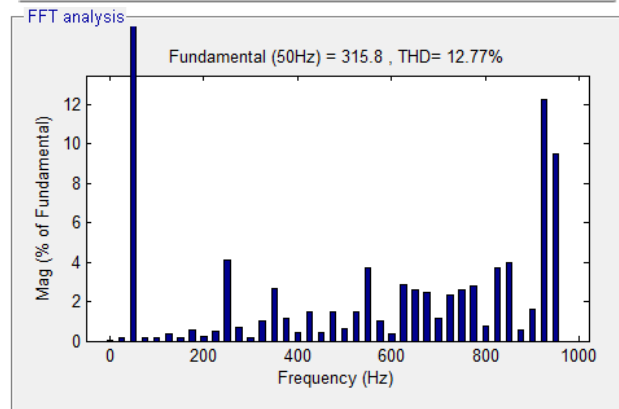
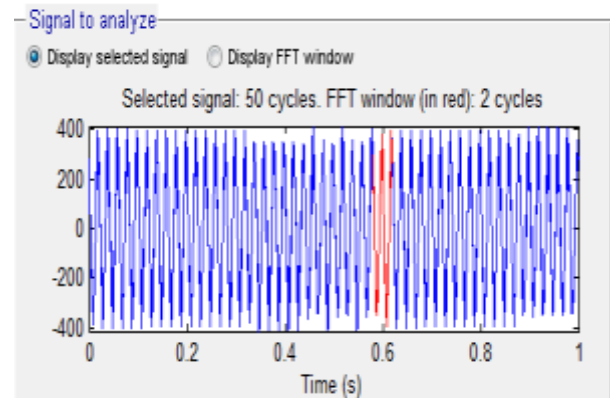

Figure (VI e)
 Figure (VI f)

Figure (VI a) output of phase1 harmonics without dynamic voltage restorer.

Figure (VI b) THD in harmonics order in phase1 without dynamic voltage restorer.

Figure (VI c) output of phase2 harmonics without dynamic voltage restorer.

Figure (VI d) THD in harmonics order in phase2 without dynamic voltage restorer.

Figure (VI e) output of phase3 harmonics without dynamic voltage restorer.

Figure (VI f) THD in harmonics order in phase3 without dynamic voltage restorer.

The simulation results carried out with dynamic voltage restorer generated harmonics are reduced. The reduced harmonics distortions in all the three phases is shown using FFT analysis in Figure (VII)

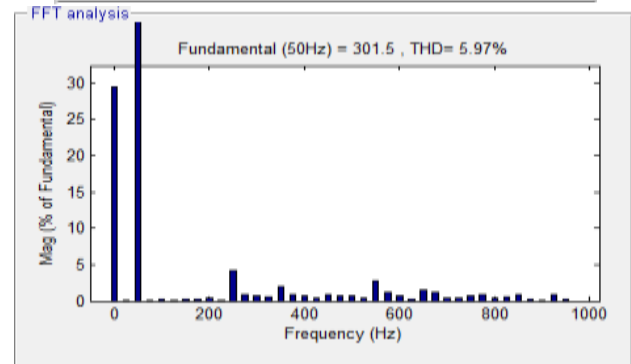
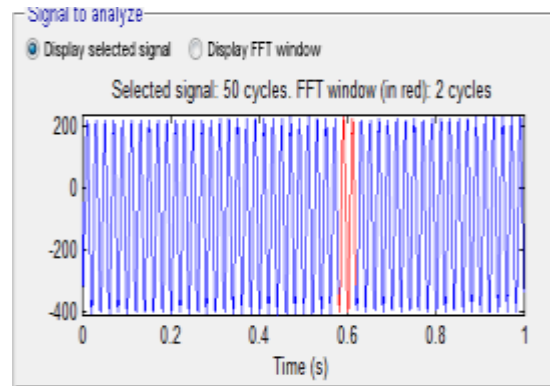

Figure (VII c)
Figure (VII d)

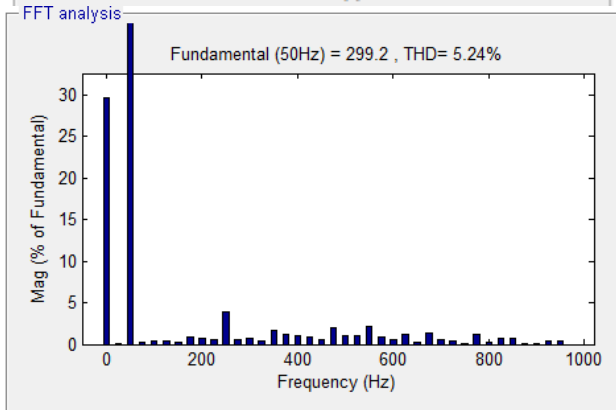
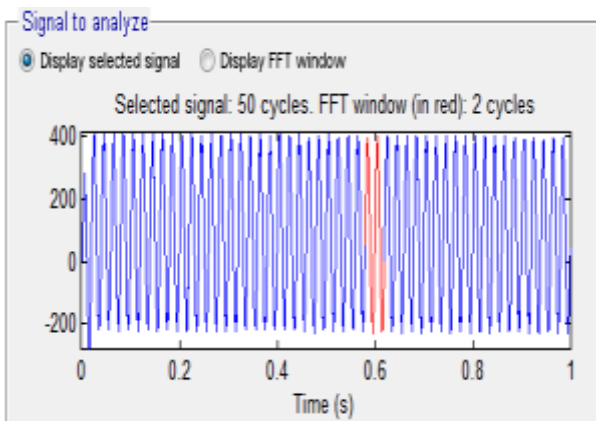

Figure (VII a)
Figure (VII b)

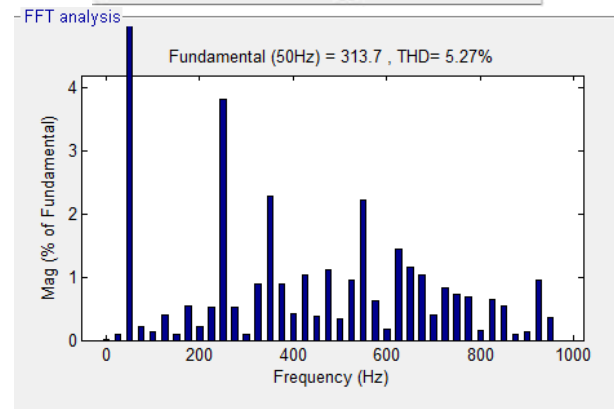
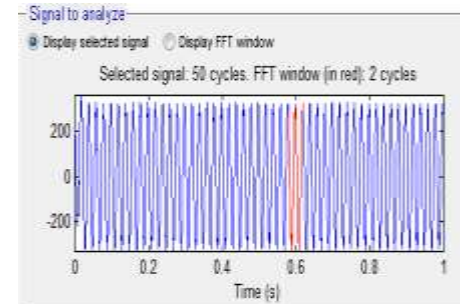

Figure (VII e)
Figure (VII f)

Figure (VII a) output of phase1 harmonics with dynamic voltage restorer

Figure (VII b) THD in harmonics order in phase1 with dynamic voltage restorer

Figure (VII c) output of phase2 harmonics with dynamic voltage restorer

Figure (VII d) THD in harmonics order in phase2 with dynamic voltage restorer

Figure (VII e) output of phase3 harmonics with dynamic voltage restorer

Figure (VII f) THD in harmonics order in phase3 with dynamic voltage restorer

The following tables show the simulation result carried out with and without using dynamic voltage restorer in mitigating harmonics.

Table 2. Sensitive Load – Before Compensation

Sr. no.	Phase	THD%
1.	Phase1	17.16%
2.	Phase2	14.99%
3.	Phase3	12.77%

Table 3. Sensitive Load – After Compensation

Sr. no.	Phase	THD%
1.	Phase1	5.24%
2.	Phase2	5.97%
3.	Phase3	5.27%

The sensitive load is protected against the distortion introduced by the main drive load and the total harmonic distortion is reduced up to 50%.

9. Conclusion

This paper has presented the power quality problems such as voltage dips, swells, distortions and harmonics. Compensation techniques of custom power electronic devices DVR was presented. The design and applications of DVR for voltage sags and comprehensive results were presented. A PWM-based control scheme was implemented. The performance of the proposed topologies and an improvement of suggested controller can be observed through simulation and experimental results. The THD and the amount of unbalance in load voltage are decreased with the application of DVR. The proposed system performs better than the traditional methods in mitigating harmonics and voltage sags.

References

1. Roger C. Dugan, Mark f. Mcgranaghan, Dr. Surya Santos and H. Wayne Beatty, "Electrical power system Quality", Tata McGraw Hills publications, 2002.
2. K. R. Padiyar, FACTS CONTROLLERS IN POWER TRANSMISSION AND DISTRIBUTION, NEW AGE INTERNATIONAL (P) LIMITED, PUBLISHERS
3. J.B Dixit, Electrical power quality S.Sadaippan, Modelling and simulation of series compensator to mitigate power quality problem, IJEST Vol. 2 (12), 2010, 7385-7394
5. Choi, S.S., Wang, T.X., and Sng, E.K.: "Power quality enhancement in an isolated power system through Series compensation". Proceedings of 15th Power System Computation Conference, Liege, Belgium, August 2005, Section 22, pp.1-7
6. Wang.T.X. and Choi S. S., "Enhancement of Voltage Quality in Isolated Power Systems" IEEE Transactions on power delivery, Vol. 22, No. 2, April 2007.
7. Leela.S, Dash. S.S., "Control of Three Level Inverter Based Dynamic Voltage Restorer" Journal of Theoretical and Applied Information Technology, Vol.8, No. 1, 2009. Pp-13-17.
8. Rosli Omar, Nasrudin Abd Rahim, Marizan Sulaiman" Modeling and Simulation for Voltage Sags/ Swells Mitigation using Dynamic Voltage Restorer (DVR)" Journal of Theoretical and Applied Information Technology, Vol.5, No. 4, 2009, pp-464-470.
9. Eng Kian Kenneth Sng, Choi, S.S., and D.Mahinda vilahgamuwa.: "Analysis of series compensation and DC-link voltage control of a transformer less self-charging Dynamic Voltage Restorer". IEEE transactions on power delivery, Vol. 19, No. 3, July 2004, pp. 1511-1518.
10. N.H.Woodley, A.Sundaram,B. CoulterandD.Morris, "Dynamic voltage restorer demonstration project experience," 12th Conf. Electric Power Supply Industry (CEPSI), Pattaya, Thailand, 1998.
11. N.H.Woodley, K.S. Berton, C.W.Edwards, B.Coulter, B.Ward, T.Einarson and A.Sundaram, "Platform mounted DVR demonstrated project experience," 5th International Transmission and Distribution Conf, Distribution 2000, Brisbane, 1999.
12. A.Ghosh and A.Joshi, "A new approach to load balancing and power factor correction in power distribution system," IEEE Trans. on Power Delivery, Vol.15, No.1, pp.417-422, 2000.
13. SPACE (DS-1104) Implementation of Detection and Control Algorithm of Dynamic Voltage Restorer (DVR) dSPACE User Conference 2012 – India | Sept 14th' 2012
14. Li, B.H., S.S. Choi and D.M. Vilathgamuwa, 2001. Design considerations on the line-side filter used in the dynamic voltage restorer: IEE Proc. Generat.Transmission Distribut., 148: 1-7.
15. Chan, K., 1998. Technical and performance aspects of a dynamic voltage restorer. In IEE Half Day Colloquium on Dynamic Voltage Restorers-Replacing Those Missing Cycles, pp: 5/1-525.
16. L.D. Zhang, M.H.J. Bollen, Characteristics of voltage dips (sags) in power systems, IEEE Int. Conf. On Harmonics and Quality of Power (ICHQP), October 1998, Athens, Greece
17. C. Zhan, V.K. Ramachandaramurthy, A.Arulampalam, C.Fitzer, S.Kromlidis, M.Barnes, N.Jenkins, "Dynamic voltage restorer based on Voltage space vector PWM control", IEEE transactions on Industry applications, Vol. 37 (No.6) Nov./Dec. 2001, pg. 1855-1863.
18. C. Zhan, V.K. Ramachandaramurthy, A.Arulampalam, C.Fitzer, M.Barnes, N.Jenkins, "Control of a battery supported dynamic voltage restorer", IEE proceedings on Transmission and Distribution, Vol. 149 (No.5), Sep.2002, pg. 533-542.

19. Hyosung Kim, Seung-Ki Sul, "Compensation voltage control in Dynamic voltage restorers by use of feed forward and state feedback scheme", IEEE transactions on Power Electronics, Vol.20, No.5, September 2005,pg.1169-1177.
20. S.S.Choi, B.H.Li, D.M.Vilathgamuwa, " Dynamic voltage restoration with minimum energy injection", IEEE transactions on Power Systems, Vol.15, No.1, February 2000, pg.51-57.
21. IEEE Recommended Practices and Requirements for Harmonic Control in Electrical Power Systems.
22. Application of Dynamic Voltage Restorer for Voltage Balancing with ASD Load Using DQO Transformation IJEE Anmol and Parag Nijhawan
23. Awad,H., Svensson,J., & Bollen, M. H. "Static series compensator for voltage dips mitigation," IEEE Bologna PowerTech Conf, Bologna, 2003.
24. S. M. Silva, L.N. Arruda and B. de J. Cardoso Filho, "Wide bandwidth single and three-phase PLL structure for utility connected system", 9th European conference on power electronics and Applications. EPE2001. Graz, Austria. August 2001.
25. G. Hsieh, and J.C. Hung, "Phase-locked Loop techniques –a survey", IEEE Trans. On Industrial Electronics, vol. 43, no. 6, pp. 609-915. 1996.
26. P. Boonchiam and N. Mithulanathan Simple Design Criteria of Injection Transformer for the Dynamic Voltage Restorer *GMSARN International Conference on Sustainable Development*
27. Turhan Demiray Simulation of Power Systems Dynamics using Dynamic Phasor Models X SEPOPE
28. Mr. Subhro Paul¹, Pradip Kumar Saha, Power Quality Improvement Using New Control Algorithm Based Dynamic Voltage Restorer *IJAREE Vol. 1, Issue 3, September 2012*
29. Insulated Gate Bipolar Transistor (IGBT) Basics Abdus Sattar, IXYS Corporation
30. U. Vidhu krishnan¹, M. Ramasamy² An Enhancement Method for the Compensation of Voltage Sag/Swell and Harmonics by Dynamic Voltage Restorer *International Journal of Modern Engineering Research (IJMER) Vol.2, Issue.2, Mar-Apr 2012 pp-475-478*