

Experimental Overview of Injector Orientation, Nozzle Hole Geometry on Performance Emission and Combustion of a DI Diesel engine

Dr. Balasubbramanian Kalyanam

Professor/Guide

*Mechanical Department, Meenakshi Sundararajan Engineering College
No:363, Arcot Road, Kodambakkam, Chennai-24 ,Tamil Nadu, India*

baaloo1953@gmail.com

Abhinav Balaji, K.Vignesh, M,Shashank

Co-Authors

*Mechanical Department, Meenakshi Sundararajan Engineering College
No:363, Arcot Road, Kodambakkam, Chennai-24,Tamil Nadu, India*

babhinav@gmail.com , k.vignesh7894@gmail.com, shashank.manghat@gmail.com

I.ABSTRACT

In this work the combined effect of injector orientation and nozzle hole geometry on performance, emissions and combustion were analyzed. Experiments were carried out on a single cylinder DI diesel engine for different orientation of injector located nearer to intake and exhaust valve in the combustion chamber. Effects of increase in injector opening pressure and injection timing advance were also analyzed. Experiments were carried out by plugging one of the two injector mounting holes. It was observed that for the injector located nearer to the exhaust valve, the combination of static injection timing 26° BTDC and injector opening pressure of 230 bar was found effective in reducing NO_x levels with no significant drop in performance. Advancing the injection timing to 29° BTDC with 230 bar injector opening pressure resulted in marginal increase in performance and reduction in Smoke levels by 0.4 Bosch Smoke Unit Number (BSN). NO_x emissions were slightly higher than that of baseline. Drop in brake thermal efficiency and increase in smoke emission levels observed for the injector located nearer to intake valve. Performance and smoke levels are inferior to that of conventional baseline reading even after the injection timing

advance. Increase of smoke by 1.6 Bosch Smoke Number (BSN) is observed at full load for the injection timing of 29° BTDC. Significant increase in Hydrocarbon and Carbon Monoxide emissions were also observed. In general it is observed that the injector location nearer to the exhaust valve has a very good potential for reducing Oxides of Nitrogen emissions without affecting the performance.

Keywords: Injector Orientation, NO_x, Smoke

II. INTRODUCTION

Combustion in diesel engines mainly depends on the mixing of air and fuel droplets inside the combustion chamber. In the direct injection diesel engines there are regions where the fuel concentrations are close to that of stoichiometric mixture ratio. This condition results in increase in the combustion temperature and hence more NO_x is produced. On the other hand, in regions where the fuel concentrations are rich, the lack of oxygen causes smoke to occur. Reduction of NO_x and Smoke levels without any compromise in performance is a real challenge. Many researchers are working in reducing NO_x emissions without decrease in efficiency with acceptable smoke levels. Use of

high pressure injection systems with multiple injections simultaneously reduces the NO_x and Smoke emissions with improved performance. A small quantity of fuel is injected during the delay period followed by main injection. It is reported that the rate of pressure rise is gradual which results in reduction in NO_x and the combustion noise levels. Post injection usually reduces the smoke emissions and pre injection is used to control the NO_x emissions. Increase of pre injection quantity increases the rate of pressure rise and there by increases the NO_x levels [1-4]. Generally in DI diesel engines the injector will be located to the centre of piston bowl for even distribution of sprays. But M.A.N type combustion system is an exemption, which will be having the injector nearer to the side walls of the combustion chamber. One of the sprays will be impinging the walls tangentially and evaporates gradually. Ignition starts adjacent to the walls and gradually spreads off [5-6]. Some researchers make use of side injectors for better distribution of fuel inside the combustion chamber. It is reported that the specific fuel consumption and smoke levels are reduced by maintaining low NO_x levels when the fuel injected from side injectors is equivalent to 20 % of total fuel injected [7]. The aim of the present work is to optimize injector orientation for NO_x reduction without affecting the performance and to deepen the understanding of diesel combustion.

III.EXPERIMENTAL SETUP

A single cylinder direct injection air cooled diesel engine was taken for the research work. The details of the research engine are given in Table1.

TABLE 1: ENGINE SPECIFICATIONS

1	Make	Kirloskar
2	Model	TAF-1
3	No of Cylinders	One
4	Type of Cooling	Air Cooled
5	Bore	87.5 mm
6	Stroke	110 mm
7	Compression Ratio	17.5:1
8	Piston Bowl	Hemispherical
9	Rated Speed	1500 Rpm
10	Rated Power	4.4 kW @1500 rpm
11	Fuel Oil	High speed Diesel (HSDO)
12	Lubrication Oil	SAE 40

The engine cylinder head modification is shown in Fig. 1. Here instead of a centrally located injector hole, an offset

was provided from the center of the bowl .Two holes were drilled on either side of the bowl center one nearer to the exhaust valve and other nearer to the intake valve. A five hole nozzle (VCO type) was used in order to reduce the local spray concentrations inside the bowl. The injector details are given in Table 2.

TABLE 2: FUEL INJECTOR SPECIFICATIONS

Conventional Injector

Make	MICO (with sac volume)
No of holes	3
Spray angle	116 deg
Injector opening pressure	200 bar
Nozzle hole diameter	0.25 mm

Modified conditions

Make	MICO (VCO type)
No. of holes	5
Spray angle	146 deg
Nozzle hole diameter	0.21 mm
Injector opening pressures	200 bar and 230 bar

The schematic layout of the experimental setup is shown in Fig. 2. Included in this schematic is the engine, air instrumentation, emission measurement analyser metering system.

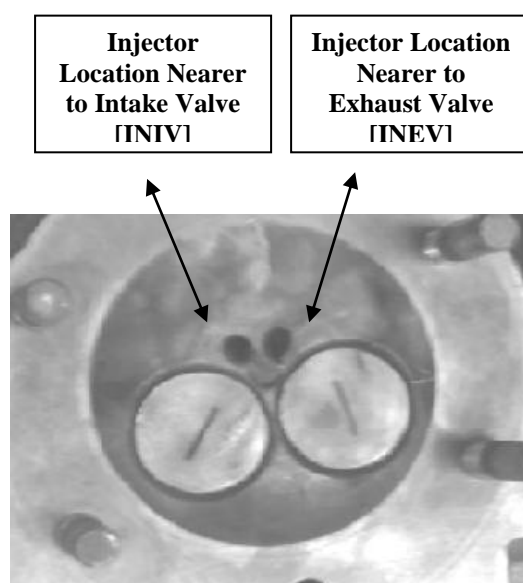

FIG 1: CYLINDER HEAD WITH TWO INJECTOR MOUNTING HOLES

Air flow rate was measured by means of orifice meter. A Piezo electric transducer [Kistler] was used for obtaining the cylinder pressure data and was amplified by means of a charge amplifier [Kistler 5015A type, sensitivity 79 pC/bar]. The dynamometer used to load the engine comprises of a shunt-wound DC generator and load bank. An interrupt counter was provided to measure the crank angle position and the output was fed to one terminal of the digital ray oscilloscope. An exhaust gas analyzer (Qrotech) was used for measuring the exhaust pollutants where NO_x and Oxygen concentrations were measured and it is an electro chemical cell. Hydrocarbons, Carbon Monoxide and Carbon dioxide were measured in NDIR type analyser. Exhaust gas temperature was measured by means of a thermocouple. Smoke levels were measured using a Bosch smoke meter.

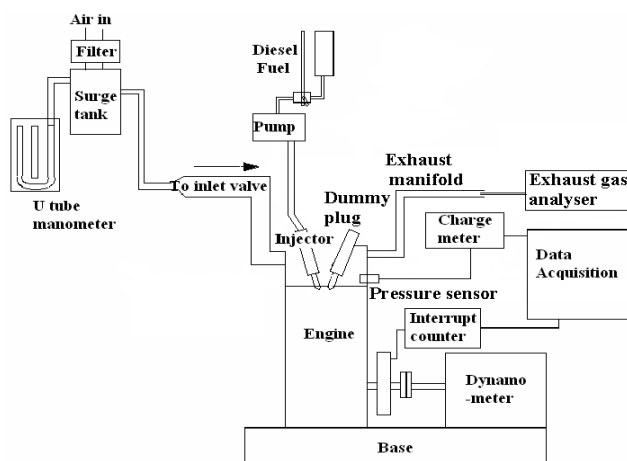

FIG 2: SCHEMATIC LAYOUT OF EXPERIMENTAL SETUP

IV. EXPERIMENTAL METHODOLOGY

In the work, engine was operated at a constant speed of 1500 rpm and load was varied from zero to full load. The tests were conducted in following phases. The operating parameters are given in table 3.

- In the first phase performance and emission characteristics were observed for the centrally located injector for providing the baseline reading.
- In the second phase, the original cylinder head was replaced with the modified one. Here the injector mounting hole nearer to the intake valve was plugged. Performance emission and combustion characteristics were observed for the injector mounted nearer to the exhaust valve. Effects of injection timing advance as well as increase in injector opening pressure have also been studied.
- In the third phase, the injector mounting hole nearer to the exhaust valve was plugged and the injector was located nearer to the intake valve.

Performance emission and combustion characteristics were observed.

TABLE. 3 OPERATING PARAMETERS

Sl No	Injector Location	Static Injection Timing (BTDC)	Injector opening pressure (bar)
1	Centre of piston bowl (Conventional)	23°	200
2	Nearer to Exhaust valve	26°	200
		29°	200
3	Nearer to Intake Valve	230	200
		26°	200
		29°	200
			230

V. RESULTS AND DISCUSSION

A. Brake Thermal Efficiency

The variation of brake thermal efficiency with brake power is shown in Fig 3. It can be seen that for all the cases maximum brake thermal efficiency occurs at 4 kW power. The drop in efficiency at full load is because of deterioration in combustion which is clearly evident from smoke emission. The brake thermal efficiency for the baseline at the rated power is 29.8 %. With the injector located nearer to the exhaust valve the brake thermal efficiency for 200 bar injector opening is lower than that of baseline and its value at rated power is 28 %. Efficiency is about 29 % for injector opening pressure of 230 bar which is very close to that of baseline reading. This is mainly due to the fact that increase in fuel injection pressure, improves the atomization which results in better combustion. On the other hand, the injector as located nearer to the intake valve shows a drop in brake thermal efficiency. The efficiency is about 25.7 % and 26.8 % for 200 bar and 230 bar injector opening pressures respectively. This may be mainly due to improper air entrainment in that location.

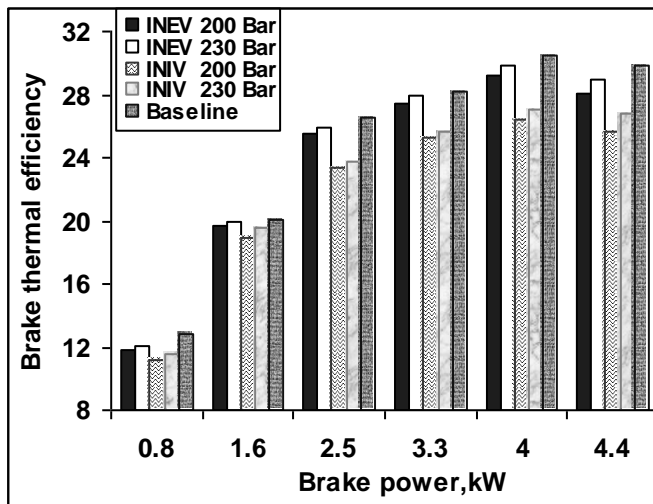

FIG. 3 VARIATION OF BRAKE THERMAL EFFICIENCY WITH BRAKE POWER AT STATIC INJECTION TIMING OF 26° BTDC

To improve the performance further, the injection timing is advanced from 26° BTDC to 29° BTDC. Fig. 4 shows the variation of brake thermal efficiency with brake power. The efficiency is increased, as the injector is located nearer to exhaust valve for the injector opening pressure of 230 bar. The maximum brake thermal efficiency obtained is at 4 kW brake power for both 200 bar and 230 bar injector opening pressure and are about 30.1 % and 31 % respectively. The efficiency is almost equal to that of baseline with the injector opening pressure of 200 bar. The efficiency at the rated power is about 29.5 % and 30.5 % for the injector opening pressures of 200 bar and 230 bar. Here the injection timing advance helps better mixing of fuel with air which results in better combustion. Also the higher rate of injection due to the increase in injector opening pressures increases the premixed combustion phase and there by increasing the efficiency. In case of injector located nearer to the intake valve, efficiency is improved compared with that of before advance, but still lower than that of baseline. The efficiency at 4 kW power are about 28.2 %, 28.9 % for the injector opening pressures of 200 bar and 230 bar. At part load conditions only a marginal reduction in efficiency is identified. This clearly reveals the improper air entrainment created due to very high local rich regions at the rated power.

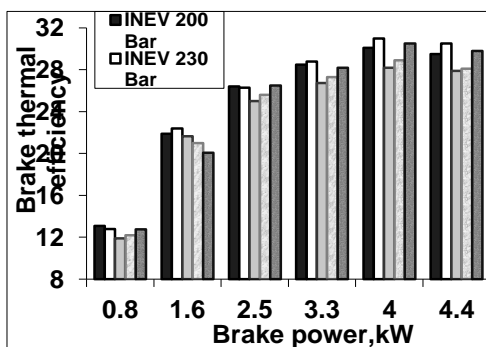

FIG. 4 VARIATION OF BRAKE THERMAL EFFICIENCY WITH BRAKE POWER AT THE STATIC INJECTION TIMING OF 29° BTDC

B. Specific Fuel Consumption

The variation of specific fuel consumption with brake power at the static injection timing of 26° BTDC is shown in Fig. 5. The specific fuel consumption for the injector located nearer to the exhaust valve is closer to that of baseline. The lowest specific fuel consumption is about 0.280 kg/kWh at 4 kW power. The injector when located nearer to the exhaust valve, in combination with the injector opening pressure of 230 bar is very effective in bringing down the fuel consumption. The SFC is about 0.285 kg/kWh which is very closer to that of baseline. The specific fuel consumption is on the higher side, as the injector is located nearer to the intake valve. Specific fuel consumption at 4 kW power is about 0.317 and 0.31 kg/kWh for the injector opening pressures of 200 and 230 bar respectively.

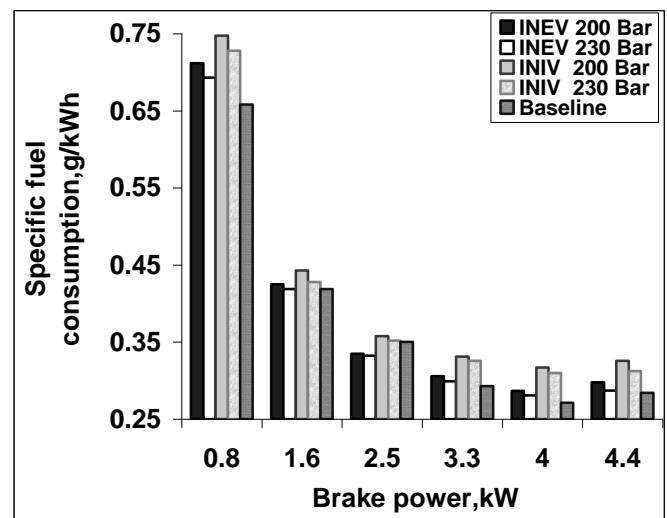

FIG. 5 VARIATION OF SPECIFIC FUEL CONSUMPTION WITH BRAKE POWER AT STATIC INJECTION TIMING 26° BTDC

The Variation of Specific fuel consumption with brake power at the static injection timing of 29° BTDC is shown in Fig. 6. Specific fuel consumption is lower than that of the baseline. The lowest specific fuel consumption is obtained for 4 kW brake power with the injector when located nearer to the exhaust valve. The SFC is about 0.2837 kg/kWh and 0.2744 kg/kWh for 200 bar and 230 bar injector opening pressures respectively. Specific fuel consumption is higher than that of the baseline for the injector located nearer to intake valve. SFC is about 0.33 kg/kWh and 0.31 kg/kWh for the injector opening pressures of 200 and 230 bar respectively.

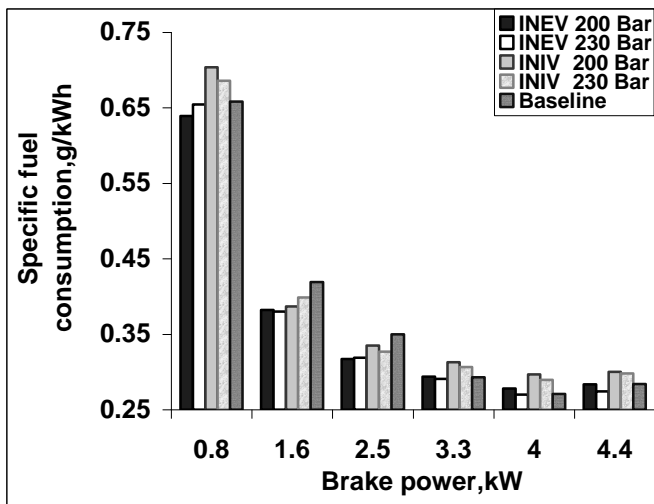

FIG. 6 VARIATION OF SPECIFIC FUEL CONSUMPTION WITH BRAKE POWER AT STATIC INJECTION TIMING 29° BTDC

C. Exhaust Gas Temperature

The variation of exhaust gas temperature with brake power for the static injection timing of 26° BTDC is shown in Fig. 7. It varies linearly with increase in brake power and reaches its maximum at the rated power. It is around 450°C for the centrally located injector (baseline). As the injector is located nearer to the exhaust valve, the exhaust gas temperatures are about 475°C and 468°C for the injector opening pressures of 200 and 230 bar respectively. The exhaust gas temperatures are increased further when the injector located nearer to the intake valve. Maximum exhaust gas temperature is about 495°C for the injector opening pressure of 200 bar. The increase in exhaust temperature clearly indicates late combustion, which may be due to the insufficient mixing time as well as the lack of air available for the individual fuel sprays at this location.

Exhaust gas temperature variation with brake power for the static injection timing of 29° BTDC is shown in Fig. 8. Due to the injection timing advance, late combustion is reduced and thereby reducing the exhaust gas temperature. The above said is clearly evident from the Fig. 8. The exhaust gas temperature for injector located nearer to the exhaust valve is almost closer to that of diesel. The exhaust gas temperatures at the rated power are about 463°C and 455°C for the injector opening pressures of 200 bar and 230 bar. The exhaust gas temperature at the rated power for the baseline is about 450°C. This clearly shows that late combustion has been reduced significantly because of the advance in injection timing. The exhaust gas temperature is on the higher side in case of injector located nearer to the intake valve. The exhaust gas temperatures at the rated power are about 478°C and 470°C for the injector opening pressures of 200 and 230 bar. This rise in exhaust temperature clearly indicates the late combustion. This may

be due to the shortage of air available for the individual fuel sprays at this location.

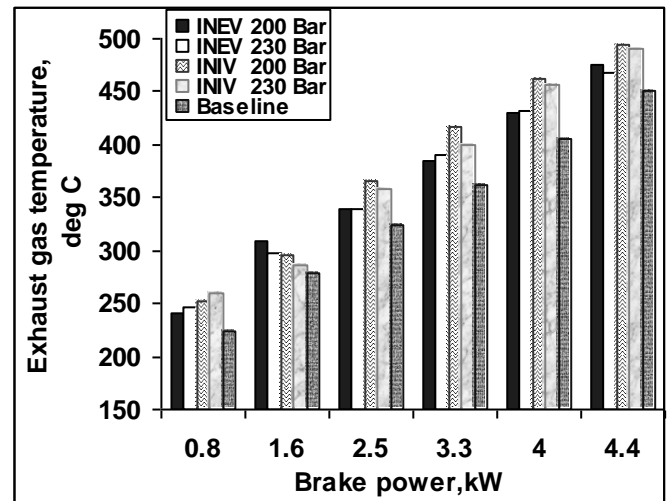

FIG. 7 VARIATION OF EXHAUST GAS TEMPERATURE WITH BRAKE POWER AT STATIC INJECTION TIMING 26° BTDC

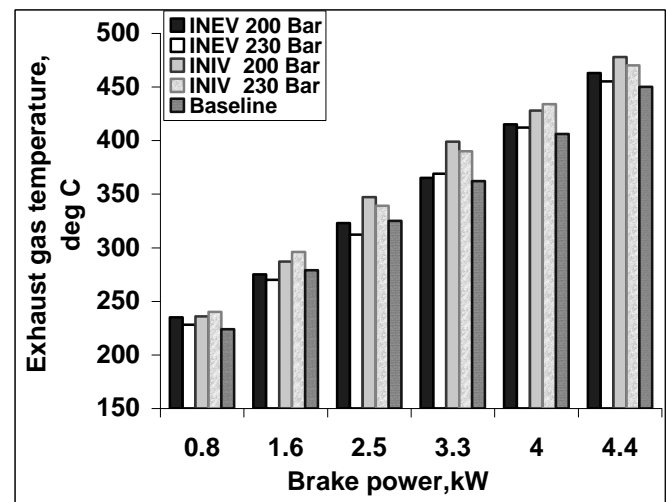

FIG. 8 VARIATION OF EXHAUST GAS TEMPERATURE WITH BRAKE POWER AT STATIC INJECTION TIMING 29° BTDC

D. EMISSIONS

1) Oxides of Nitrogen:

Fig. 9 shows the variation of NO_x with Brake power for the injection timing of 26° BTDC. NO_x emission at the rated power is about 14.623 g/kWh for the baseline. At the rated power, with the injector located nearer to the exhaust valve, it is about 10.943 g/kWh for the injector opening pressure of 200 bar. The NO_x emission is about 11.344 g/kWh for the injector opening pressure of 230 bar. Increase in injector opening pressure increases the rate of injection which in turn increases the burning rate resulting in high local temperatures. This may be the reason for the increase in NO_x emissions with the injector opening pressure of 230 bar. At

75 % of the rated power the NO_x emissions are about 13.218 and 13.618 g/kWh for the injector opening pressures of 200 and 230 bar. For the baseline it is about 14.623 g/kWh at 75 % of rated power. The injector located nearer to the intake valve gives the best in reducing the NO_x levels but with penalties in smoke. The NO_x emissions are observed to be 9.35 and 8.96 g/kWh for 200 and 230 bar pressures respectively at the rated power. At 75% of the rated power the NO_x emissions are about 12.9 and 12.6 g/kWh for the injector opening pressures of 200 and 230 bar. For the centrally located injector (baseline) the NO_x emission at 75 % of rated power is about 14.623 g/kWh. The reduction in the NO_x emission is because of the deterioration in combustion at the rated power. It is clear that for all the cases, NO_x levels are lower than that of the centrally located injector (baseline). Flame quenching near the side walls may be another reason for this overall reduction in NO_x level. As the injector is at an offset from the centre of the bowl the flame quenching distance is shorter compared with that of the centrally located injector.

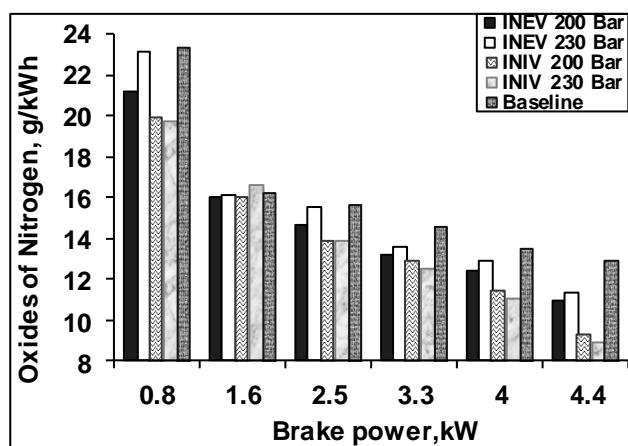

FIG. 9 VARIATION OF OXIDES OF NITROGEN WITH BRAKE POWER AT STATIC INJECTION TIMING OF 26° BTDC

The variation of NO_x with brake power at the injection timing of 29° BTDC is shown in Fig. 10. In case of the injector located nearer to the intake valve the NO_x emissions at the rated power is slightly lower compared to that of baseline with the injector opening pressure of 200 bar. NO_x emissions are slightly increased with the injector opening pressure of 230 bar compared with that of baseline. The NO_x emissions at the rated power are about 12.785 and 13.618 g/kWh for the injector opening pressures of about 200 bar and 230 bar respectively. The increase in NO_x level is due to the increase in premixed combustion phase as a result of injection timing advance. NO_x levels are still lower than that of baseline as the injector is located nearer to the intake valve. The NO_x emission at the rated power for 200 bar opening pressure is about 11.024 g/kWh. Only a marginal increase in NO_x level is observed for the injector opening pressure of 230 bar. The NO_x level is about 11.386 g/kWh for the injector opening pressure. At 75 % of rated power the NO_x levels are about 13.314 and 14.025 g/kWh for the

injector opening pressures of 200 and 230 bar. The NO_x level for the baseline at 75 % of rated power is about 14.623 g/kWh.

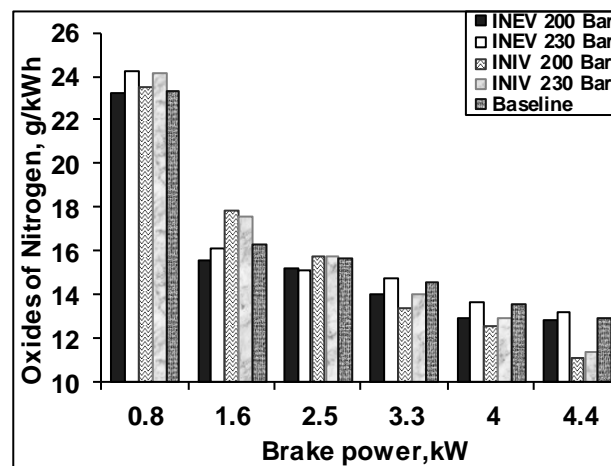

FIG. 10 VARIATION OF OXIDES OF NITROGEN WITH BRAKE POWER AT STATIC INJECTION TIMING OF 29° BTDC

2) Smoke:

Fig. 11 shows the variation of smoke with brake power. The smoke emission at the rated power is about 2.8 Bosch Smoke Number (BSN), with the injector located nearer to the exhaust valve. This is achieved with the injector opening pressure of 200 bar. Best results in smoke reduction are achieved with the combination of 230 bar. At the rated power it is about 2.4 BSN. Increase in injector opening pressure finer the atomization which leads to better combustion. The smoke level at the rated power is about 2.0 BSN for the baseline. At 75 % of the rated power the smoke levels are about 1.2 BSN and 1 BSN for the injector opening pressures of 200 bar and 230 bar. The smoke emission at 75 % of the rated power is about 0.6 BSN for the baseline. Smoke levels are on the higher side when the injector is mounted nearer to the intake valve. The smoke levels are 4.6 and 5 BSN for 230 and 200 bar opening pressures respectively. Even at part loads smoke levels are much higher than that of baseline. This reveals the fact that air motion and air entrainment is not proper at the location nearer to the intake valve.

To improve the mixing, the injection timing is further advanced to 29° BTDC. Injection timing advance promotes better mixing of fuel and air which results in smoke reduction. The variation of smoke with brake power is depicted in Fig. 12. Results are better in case of the injector located nearer to the exhaust valve. Smoke emission is reduced to 1.6 BSN which is even lower than that of centrally located injector (baseline). Due to injection timing advance, better mixing of air and fuel sprays is possible which results in reduction in smoke emission. The increase in injector opening pressure is also attributed for this smoke reduction. Decreasing the injector opening pressure to 200 bar marginally increases the smoke. The smoke level at the rated

power is about 2 BSN which is similar to that of baseline. Smoke levels are on the higher side compared to that of baseline in case of the injector located nearer to the intake valve. The smoke levels at the rated power are about 3.6 and 3.2 for the injector opening pressures of 200 and 230 bar respectively. Smoke emissions are still significant at part loads. This reveals that more local fuel rich zones are present which is clearly due to the improper fuel distribution in this location.

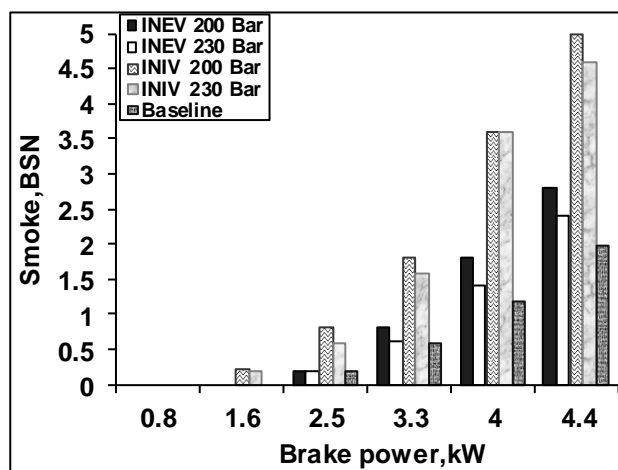

FIG. 11 VARIATION OF SMOKE WITH BRAKE POWER AT STATIC INJECTION TIMING OF 26° BTDC

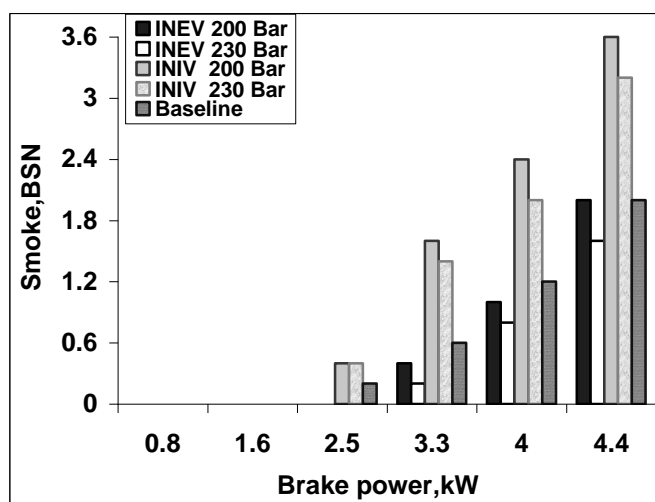

FIG. 12 VARIATION OF SMOKE WITH BRAKE POWER AT STATIC INJECTION TIMING OF 29° BTDC

3)Hydrocarbons:

The variation of Hydrocarbon emissions with brake power for the static injection timing of 26° BTDC is shown in Fig. 13. More HC emissions are expected for the injector nearer to intake and exhaust valve as the quenching effect is predominant at these locations. But on contrary the HC

emissions are lower compared to that of the centrally located injector with the injector located nearer to that exhaust valve. The hydrocarbon emissions at the rated power are about 0.055 and 0.06 g/kWh for the injector opening pressures of 230 and

200 bar. It is about 0.062 g/kWh for the baseline at the rated power. The HC levels are significantly lower at the part loads compared to that of baseline. One of the reasons may be sufficient time is available for oxidation of the unburned hydrocarbons during late expansion stroke. Another reason may be because of the Valve Covered Orifice (VCO) type nozzle. The contribution of hydrocarbon emissions from the Nozzle Sac volume is reduced. On the other hand HC emissions are on the higher side for the injector located nearer to the intake valve. The HC emissions at the rated power are about 0.092 and 0.085 for the injector opening pressures of 200 and 230 bar. Very high local concentrations created due to improper air entrainment may be the reason for this increase in HC levels. But at part load conditions the HC emissions are closer to that of baseline.

The variation of hydro Carbon emissions with brake power at the static injection timing of 29° BTDC is shown in Fig.14. The HC levels at part loads are comparably lower than that of baseline in case of the injector located nearer to the exhaust valve. The HC emissions at 3.3 kW are about 0.07 and 0.06 g/kWh. It is about 0.075g/kWh for the baseline. Due to injection timing advance the fuel air mixing is better which results in better combustion at the part load conditions. The HC emissions at the rated power are about 0.05 g/kWh for both the injector opening pressures. The HC level is about 0.055 g/kWh for the baseline at the rated power. With the injector located nearer to the intake valve the hydrocarbon emissions at the rated power are on the side. The HC emissions are about 0.085 and 0.08 g/kWh for the injector opening pressures of 200 and 230 bar. The reason for the increase in HC level is due to local fuel rich zones created due to the location of the injector.

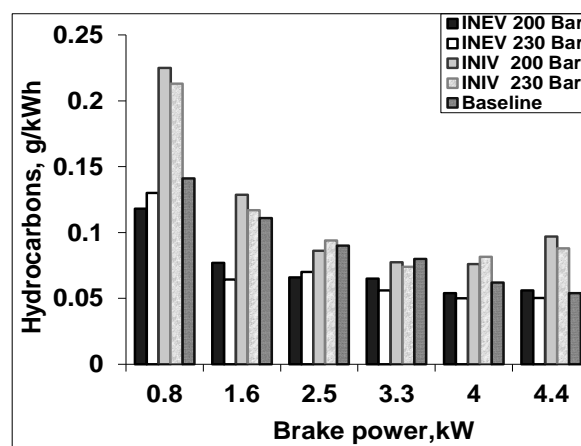

FIG. 13 VARIATION OF HYDROCARBON WITH BRAKE POWER AT THE STATIC INJECTION TIMING OF 26° BTDC

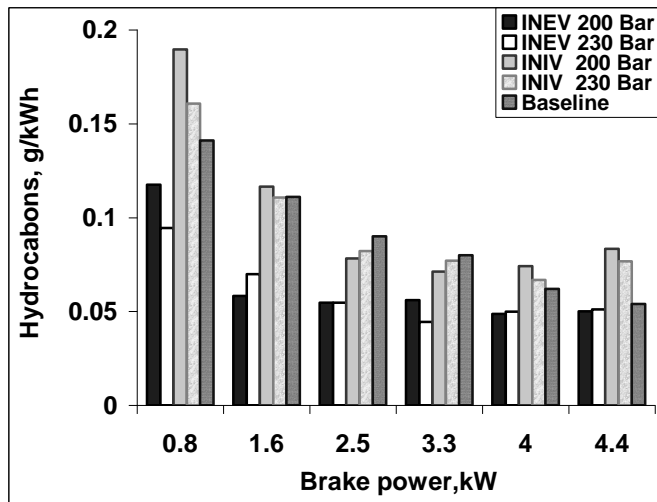

FIG. 14 VARIATION OF HYDROCARBON WITH BRAKE POWER AT THE STATIC INJECTION TIMING OF 29° BTDC

4) Carbon Monoxide:

Fig. 15 shows the variation of carbon monoxide emissions with brake power. It is clearly evident that the CO emissions are on the higher side for the injector located nearer to the intake valve. Increase in injector opening pressures is not having much significance on CO emissions. The CO levels are about 0.082 and 0.079 g/kWh for the injector opening pressures of 200 and 230 bar respectively. The increase in CO levels is due to incomplete combustion. The CO levels at the rated power for the baseline are about 0.019 g/kWh. As the injector is located nearer to the exhaust valve, the CO emissions are very much lower while compared to the location nearer to the intake valve. The CO levels are about 0.05 and 0.048 g/kWh for the injector opening pressures of 200 and 230 bar respectively. The CO emissions at rated power are significantly higher than that of baseline for the injection timing of 26° BTDC. But at part load conditions only a marginal increase in CO is observed. The increase in CO emission at rated power is attributed to insufficient oxidation created due to increase in fuel air ratio.

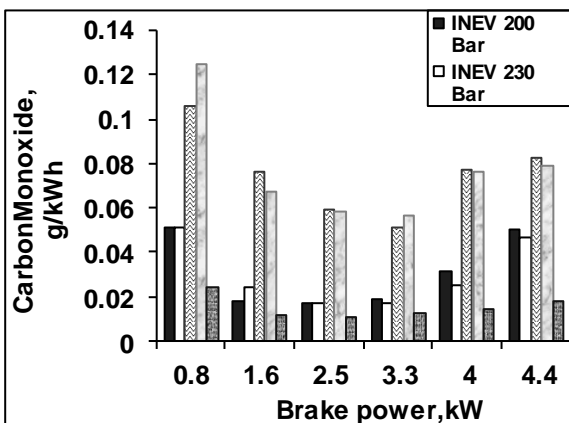

FIG. 15 VARIATION OF CARBONMONOXIDE WITH BRAKE POWER AT THE STATIC INJECTION TIMING OF 26° BTDC

Injection timing advance proves effective in reducing the CO emission. The variation of carbon monoxide with brake power for the injection timing of 29° BTDC is shown in Fig. 16. The CO emission is almost the same as that of the baseline for the nozzle opening pressure of 230 bar. This is for the case of injector located nearer to the exhaust valve. The CO levels are about 0.026 and 0.02 g/kWh for the injector opening pressures of 200 and 230 bar respectively. Increase in injector opening pressure increases the penetration of fuel sprays in air which results in better exposure of fuel droplets to air. The CO levels are on the higher side in case of injector located nearer to the intake valve. The CO levels at the rated power are about 0.075 and 0.07 for the injector opening pressures of 200 and 230 bar. Even at the part load conditions CO levels are on the higher side compared with that of the baseline.

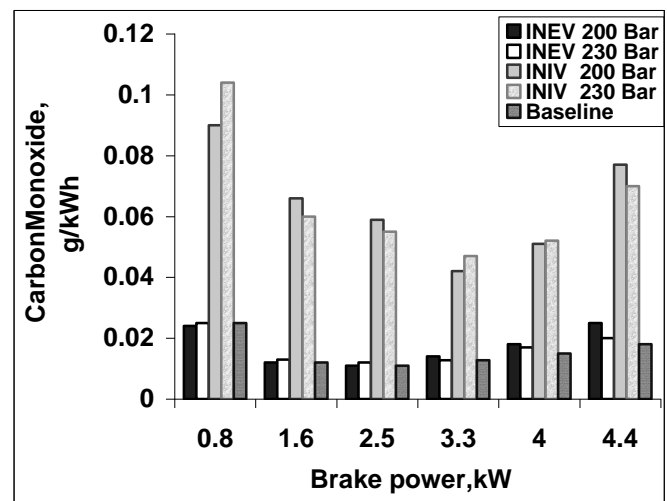

FIG. 16 VARIATION OF CARBONMONOXIDE WITH BRAKE POWER AT THE STATIC INJECTION TIMING OF 29° BTDC

E. COMBUSTION

1) Firing Pressure:

The variation in firing pressure with brake power is shown in Fig. 17 for the injection timing of 26° CA BTDC. The firing pressure at the rated power is slightly lower to that of baseline, with the injector is located nearer to the exhaust valve for the injector opening pressure of 230 bar. The firing pressures at the rated power are 70.3 and 71 bar for the injector opening pressures of 200 and 230 bar. Even at part load conditions only a slight reduction in firing pressure is observed. This is attributed to the injection timing of 26° BTDC compared to 23° BTDC for the baseline. In the case of injector located nearer to the intake valve, the firing pressure is significantly lower than that of the baseline for both the injector opening pressures. The firing pressure

graph indicates a dip at rated power, which clearly indicates the deterioration in combustion. The firing pressures at the rated power are about 65.5 bar for both the injector opening pressures. The reduction in cylinder firing pressure is because of the deterioration in combustion due to the formation of smoke.

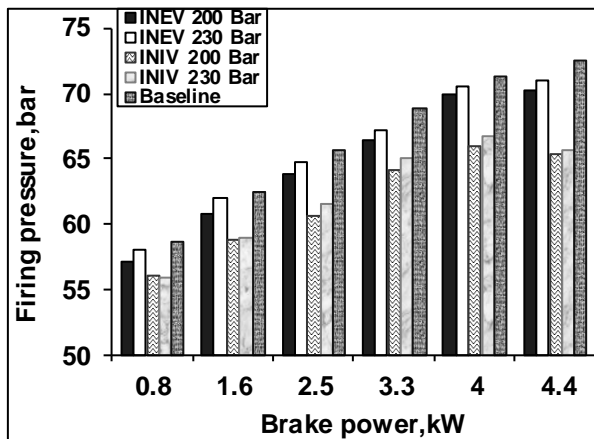

FIG. 17 VARIATION OF FIRING PRESSURE WITH BRAKE POWER AT STATIC INJECTION TIMING OF 26° BTDC

Fig. 18 shows the variation of firing pressure with brake power at the static injection timing of 29° BTDC. The firing pressure at the rated power for the baseline is about 72.7 bar. In case of the injector located nearer to the exhaust valve, the firing pressures at the rated power are 72.5 bar and 73.1 bar for the injector opening pressures of 200 and 230 bar respectively. The increase in firing pressure is due to the increase in premixed combustion phase created by the injection timing advance. In case of injector located nearer to the intake valve, the firing pressures are significantly lower than that of the baseline for both the injector opening pressures. The firing pressures are about 67.1 bar and 68.2 bar for the injector opening pressures of 200 and 230 bar respectively. The increase in firing pressure for the injector opening pressure of 230 bar is due to the increased rate of injection during the premixed combustion phase which results in an increase in firing pressure.

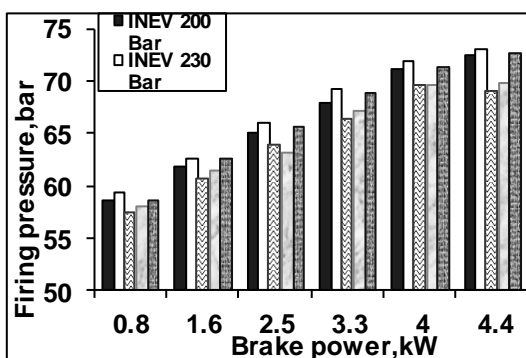

FIG. 18 VARIATION OF FIRING PRESSURE WITH BRAKE POWER AT STATIC INJECTION TIMING OF 29° BTDC

2) Pressure-Crank Angle:

The area under the pressure-crank angle curve generally shows the nature of combustion. Generally larger the area, higher will be the efficiency. But the point where the maximum pressure is occurring plays a major role in engine efficiency. The variation of cylinder pressure with crank angle is shown in Fig. 19. The maximum pressure at the rated power for the baseline is about 72.5 bar at 368° CA. The peak pressure is about 71 bar at 365° CA in case of injector located nearer to the exhaust valve which is closer to that of diesel for the injector opening pressure of 230 bar. Due to the advance the peak pressure occurs closer to that of TDC. The peak pressure is about 70 bar at 366° CA for the injector opening pressure of 200 bar. The start of pressure rise during the premixed combustion phase is attained at 12° BTDC and 11° BTDC for the injection pressures of 230 bar and 200 bar respectively. It is about 8° BTDC for the baseline. The early start of pressure rise may be due to the injection timing advance and may also be due to better dispersion of fuel in air by the five hole nozzle. The peak pressure is comparably lower in the case of injector located nearer to the intake valve. The maximum pressures attained are about 65.4 bar at 367° CA and 64 bar at 367° CA for the injector opening pressures of 200 bar and 230 bar respectively. The start of pressure rise during the premixed combustion phase is attained at 5° BTDC for the injection pressures of 230 bar and 200 bar respectively. This late start of pressure reveals the poor air fuel mixture formation at this location. Late burning is also clearly witnessed for both the injector opening pressures.

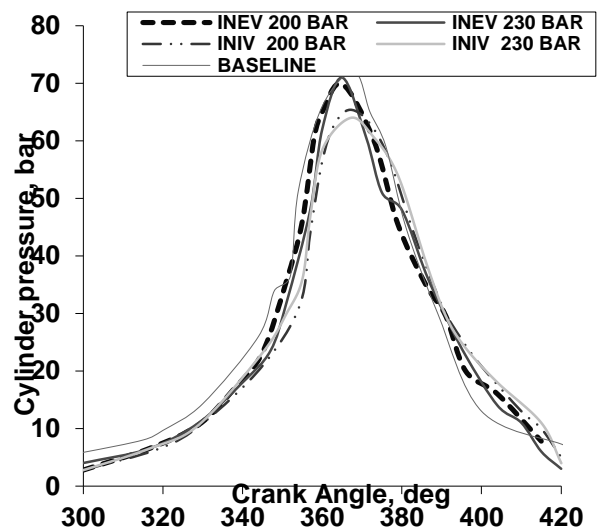

FIG. 19 VARIATION OF CYLINDER PRESSURE WITH CRANK ANGLE AT THE STATIC INJECTION TIMING OF 26° BTDC

Fig. 20 shows the variation of cylinder pressure with Crank angle at 29° BTDC injection timing. The maximum pressure is attained about 73.5 bar at 4° ATDC with the injector located nearer to the exhaust valve. For the injector opening

pressure of 200 bar, the maximum pressure is about 70.9 bar at 5° ATDC. The start of pressure rise during the premixed combustion phase is attained at 12° BTDC and 11° BTDC for the injection pressures of 230 bar and 200 bar respectively. The area under the curves is also closer to that of baseline diesel. In case of the injector located nearer to the intake valve, the maximum pressure is about 68.6 bar for the injector opening pressure of 200 bar. This pressure is attained at the crank angle of 366°. Increase in injector opening pressure increases the peak pressure. It is about 70 bar occurring at a crank angle of 367°. The start of pressure rise during the premixed combustion phase is attained at 9° BTDC and 10° BTDC for the injection pressures of 230 bar and 200 bar respectively.

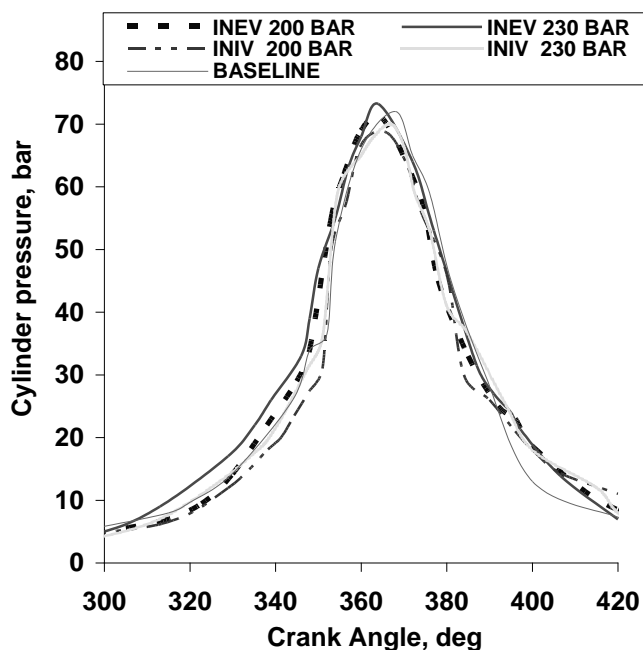

FIG. 20 VARIATION OF CYLINDER PRESSURE WITH CRANK ANGLE AT THE STATIC INJECTION TIMING OF 29° BTDC

3) Heat release rate:

The variation of heat release rate (HRR) with crank angle is shown in Fig. 21 for the injection timing of 26° BTDC. The maximum heat release rate is lower than that of baseline, with the injector located nearer to the exhaust valve. The maximum rate of pressure rise is about 74 J/deg at 4° BTDC. It is about 69 J/deg at 3° BTDC and 66 J/deg at 5° BTDC for the injector opening pressures of 200 and 230 bar respectively. The heat released just after the TDC is accounted much as far as the performance is concerned. The second peak gives the heat released during the controlled combustion phase. This is maximum for the baseline and also it is closer to TDC. The HRR is about 50 J/deg at 11° ATDC. The heat release rates are about 47 J/deg at 15° ATDC and 46 J/deg at 17° ATDC for the injector opening pressures of 200 bar and 230 bar respectively. The area under the heat release curve also plays the role in determining the performance. It is

clearly evident that, the area under the curve INEV 230 bar is closer to that of diesel. On the other hand the heat release rate is less with the injector located nearer to the intake valve. The pattern is also abrupt, which is clearly evident by the heat release during the late expansion stages. This clearly shows the air available for the sprays is insufficient, which may be due to the uneven distribution of sprays in the combustion chamber. The heat release rates during the diffusion phase of combustion are about 34 J/deg at 16° ATDC and 33.7 J/deg at 20° ATDC for the injector opening pressures of 200 and 230 bar respectively.

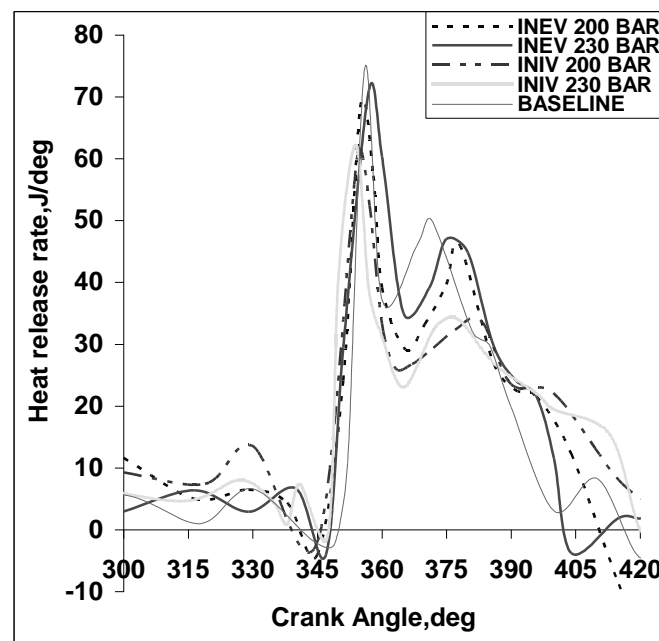

FIG. 21 VARIATION OF HEAT RELEASE RATE WITH CRANK ANGLE AT THE STATIC INJECTION TIMING OF 26° BTDC

Fig. 22 shows the variation of heat release rate with crank angle for the injection timing of 29° BTDC. Due to the advance, the rate of pressure rise is even slightly more than that of the baseline. This happens when the injector is located nearer to the exhaust valve at an opening pressure of 230 bar. The maximum heat release rate is about 77.8 J/deg attained at 5° BTDC. For the injector opening pressure of 200 bar the maximum heat release rate is about 74 J/deg attained at 6° BTDC. The maximum heat release rate during the controlled combustion phase too is slightly more than that of the baseline. The heat release rates are about 51 J/deg attained at 9° ATDC and 49 J/deg attained at 10° ATDC for the injector opening pressures of 230 and 200 bar respectively. The value is about 50 J/deg attained at 11° ATDC for the baseline. Credit should be given to the mixing time and atomization. The area of the curve is also similar to that of the baseline. Heat release rate is not matched, as the injector is located nearer to the intake valve. The heat released during the uncontrolled combustion phase is increased due to the advance in timing. But the heat release rate during the

controlled combustion phase still is lower in its magnitude while compared to that of others. The values are about 41 J/deg attained at 16° ATDC and 39 J/deg attained at 15° ATDC for the injector opening pressures of 230 bar and 200 bar respectively. Still heat release during the late expansion stroke is evident.

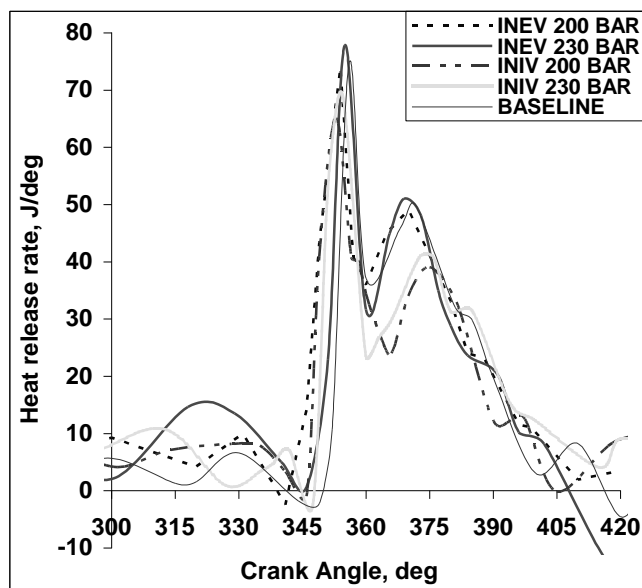

FIG. 22 VARIATION OF HEAT RELEASE RATE WITH CRANK ANGLE AT THE STATIC INJECTION TIMING OF 29° BTDC

4) Maximum Rate of Pressure Rise:

Fig. 23 shows the variation of maximum rate of pressure rise (ROPR) with brake power for the static injection timing of 26°. With the injector located nearer to the exhaust valve, the rate of pressure rise is closer to that of baseline with the injector opening pressure of 230 bar. The maximum ROPR at rated power are 4.2 J/deg and 4.28 J/deg for the injector opening pressures of 200 and 230 bar. The rate of pressure rise is lower with the injector located nearer to the intake valve. Injector opening pressures have no significant influence at part loads, but have some significant effect at full loads. The values at rated power are 3.8 J/deg and 3.95 J/deg for the injector opening pressures of 200 and 230 bar.

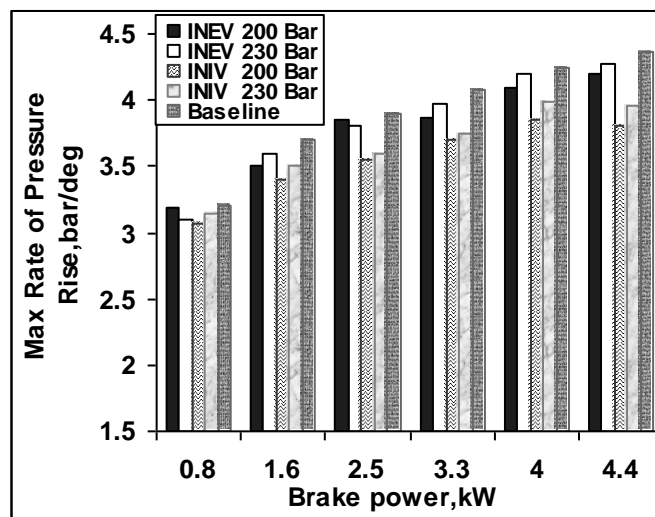

FIG. 23 VARIATION OF MAXIMUM RATE OF PRESSURE RISE WITH CRANK ANGLE AT THE STATIC INJECTION TIMING OF 26° BTDC

Fig. 24 shows the variation of ROPR with brake power at the injection timing of 29° BTDC. Only a marginal increase in rate of pressure rise is observed at the rated power with the injector located nearer to the exhaust valve. Even injector opening pressure doesn't have any appreciable influence on pressure rise. The ROPR at the rated power are 4.3 J/deg and 4.4 J/deg for the opening pressures of 200 and 230 bar respectively. With the injector located nearer to the intake valve the rate of pressure rise is lower compared with that of the location nearer to the exhaust valve. Increase in injector opening pressure will increase the rate of injection which will increase the rate of pressure rise. But at this location, it is practically having no significant influence in rate of pressure rise. The values are 3.95 J/deg and 4.0 J/deg for the injector opening pressures of about 200 and 230 bar.

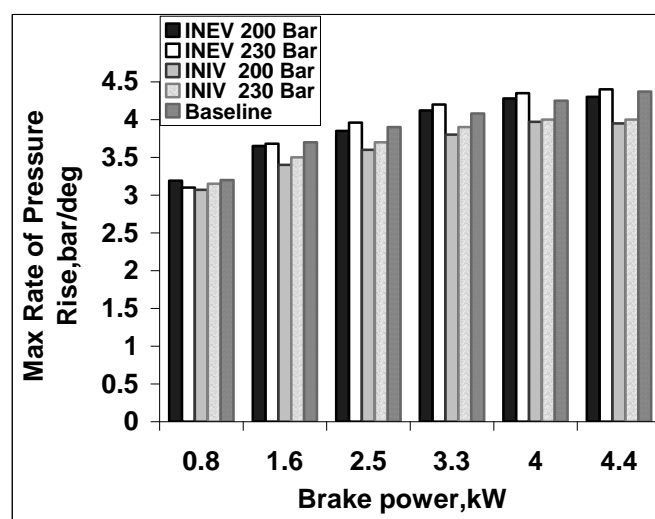

FIG. 24 VARIATION OF MAXIMUM RATE OF PRESSURE RISE WITH CRANK ANGLE AT THE STATIC INJECTION TIMING OF 29° BTDC

VI.CONCLUSION

From the experimental results following conclusions were made

A. Injector Located Nearer to the Exhaust Valve

- The combination of the static injection timing of 26° BTDC and 230 bar injector opening pressure is reducing the NOx levels by 13 % with only an increase of 0.4 BSN at the rated power. The performance is closer to that of baseline.
- The rate of heat release and the firing pressure at the rated power are slightly lower to that of baseline.
- NOx levels at the rated power are reduced by 15.5 %, with 1.8 % reduction in brake thermal efficiency for the combination of SIT 26° BTDC and injector opening pressure of 200 bar. Smoke level is increased by 0.8 BSN.
- The combination of SIT 29° BTDC and injector opening pressure of 230 bar holds good in reducing the smoke levels compared with that of baseline. Smoke levels at the rated power are reduced by 0.4 BSN. NOx levels are increased by 1.6 %. Brake thermal efficiency is increased by 2.3 %. The rate of heat release and maximum combustion pressure is also higher compared to that of baseline.
- With the combination of 29° BTDC and 200 bar performance is closer to that of the baseline.
- Smoke levels are same as that of the baseline and NOx levels are reduced by 1.6 % compared to that of baseline at the rated power.

2. Injector Located Nearer to the Intake Valve

- Maximum NOx reduction is achieved for the combination of static injection timing of 26° BTDC and 230 bar injector opening pressure. NOx levels at the rated power are reduced by 30.8 % with increase in smoke levels by 2.6 BSN compared with that of baseline. Brake thermal efficiency is decreased by 10.06 % at the rated power
- Smoke level is increased by 3 BSN at the rated power for the combination of static injection timing of 26° BTDC and 230 bar injector opening pressure compared with that of baseline.
- HC and CO levels have increased for all the injection timings and pressures.
- Heat release rate and Firing pressures increases with injection advance. But still the values are not matched with that of baseline.

On the whole it is concluded that, the location nearer to exhaust valve in combination with of the static injection

timing of 26° BTDC and 230 bar injector opening pressure proves good in all aspects. For the same location the combination of 29° BTDC and 200 bar injector opening pressure has almost the same performance and emission characteristics as that of baseline.

ACKNOWLEDGEMENTS

The authors wish to express their thanks to Mr. Janardhanan, Executive Director, Research and Development, Ms Simpson & co for providing the fuel injector.

The authors also thank Mr. Narayanan, Visa Diesel and Electric services for his assistance in bringing out this work.

ABBREVIATIONS

ATDC	=After Top Dead Center
BTDC	=Before Top Dead Center
INEV	=Injector located Nearer to Exhaust Valve
INIV	=Injector located Nearer to Intake Valve
VCO	=Valve Covered Orifice
SIT	=Static Injection Timing
NOx	=Oxides of Nitrogen
BSN	=Bosch Smoke Number
HC	=Hydrocarbons
CO	=Carbon Monoxide
ROPR	=Rate of Pressure Rise
HRR	=Heat Release Rate

REFERENCES

1. S. Kevin chen, "Simultaneous Reduction of Nox and Particulate Emissions by Using Multiple Injections in a Small Diesel Engine," SAE Paper 2000-01-3084
2. Jesus Benaes, Santiago Molina and Josem.Garcia, "Influence of Pre-and Post-injection on the performance and pollutant emissions in a HD Diesel Engine," SAE Paper 2001-01-0526
3. F. Mallamo, M. Badami and F. Millo," Analysis of Multiple Injection Strategies for Reduction of Emissions, Noise and BSFC of a DI CR Small Displacement Non-Road Diesel Engine," SAE Paper 2002-01-2672
4. Naeim A. Henein, Ming-Chia Lai, Inderpal singh, Dahai Wang and Liang Liu, "Emissions Trade-Off and Combustion Characteristics of a High Speed Direct Injection Diesel Engine" SAE Paper 2001-01-0197
5. Heywood. J.B., Internal Combustion Engine Fundamentals, McGraw-Hill, Newyork, 1998
6. Paul G. Burman and Frank Deluca," Fuel Injection and Controls for Internal Combustion Engines," The Technical Press LTd, London

